



STAIR-ROBOT® SR EXPRESS



The Stair-Robot SR Express is a battery-powered stair climbing device designed for day-to-day distribution. This compact and lightweight stairclimber can handle unit loads up to 150 Kg.

The drive unit can be used to easily lift or lower the SR Express with or without a load from a van or pick-up truck.

Two basic techniques are used to move a load up or down the stairway:

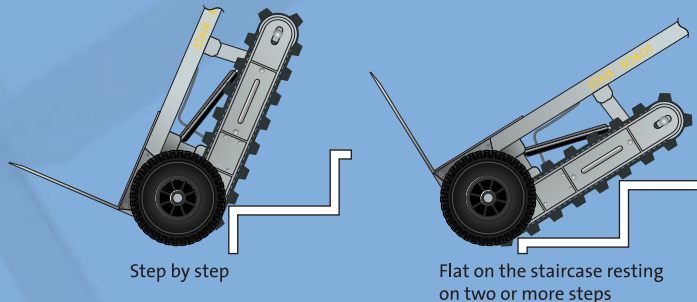

The SR Express is designed for a one man operation. It features several operator friendly functions and options including fast removable battery packs, remote control, different types of wheels, height adjustable platform and adjustable handles.

The SR Express reduces the safety risks during a stair move and minimizes the physical burden on the operator.



Handling fields:

- ▶ Washing machines
- ▶ Computers
- ▶ Crates and casks
- ▶ Refrigerators
- ▶ Copiers
- ▶ Furniture



technical data

CAPACITY

MAXIMUM CAPACITY FLAT ON STAIRCASE	150 KG (IN STRAIGHT POSITION 110 KG)
MAXIMUM CAPACITY ADJUSTABLE PLATFORM	150 KG (IN STRAIGHT POSITION 100 KG)
SPEED POSITION 1	7,5 MTR/P/MIN
SPEED POSITION 2	4,5 MTR/P/MIN
NUMBER OF FLOORS WITH 2 BATTERY PACKS	20

DIMENSIONS

DIMENSIONS CHASSIS (L) x (W) x (H)	1445 MM x 400 MM x 240 MM
WHEELBASE (W) x (H) x (T)	550 MM x 250 MM x 80 MM
DIMENSIONS DRIVE UNIT (L) x (W) x (H)	640 MM x 330 MM x 120 MM
PLATFORM (W) x (L)	390 MM x 290 MM
ADJUSTABLE PLATFORM (W) x (L)	390 MM x 290 MM
WEIGHT (WITHOUT BATTERIES)	29 KILO

ELECTRICAL SYSTEM

24 VOLT	
2 FAST REMOVABLE BATTERY PACKS 12V/ 9 AH	
250 WATT MOTOR	
CHARGING TIME BATTERIES	+/- 4 HRS
UNIVERSAL CHARGER 220/110/100 V / 24V	1,5 AH
PROGRAMMABLE MOTOR CONTROLLER	

GENERAL

- KEY-SWITCH
- BATTERY INDICATOR
- POSITIONAL DRIVE UNIT
- DOUBLE CONTROL POSITION
- TWO-SPEED OPERATION
- DOUBLE HEAVY DUTY CATERPILLAR TRACKS
- TWO-WAY OPERATION ON STAIRS:
 1. STEP BY STEP
 2. FLAT ON THE STAIRCASE RESTING ON TWO OR MORE STEPS
- LIGHTWEIGHT ALUMINIUM CHASSIS
- STAINLESS STEEL SUSPENSION
- LARGE AIR TYRES
- CAPABLE OF CLIMBING STRAIGHT STAIRS AS WELL AS QUARTER ROUND STAIRS
- MOVE A LOAD DIRECT OUT OF A VAN OR PICK-UP TRUCK

OPTIONS

- ADJUSTABLE PLATFORM
- ADDITIONAL BATTERY PACK
- REMOTE CONTROL
- SOLID RUBBER TYRES (ALSO IN GREY) Ø 250 MM AND Ø 160 MM
- RUBBER PROTECTING STRAPS
- TRUCK CHARGER
- RIGGING



Kerkstraat 79
 2377 AX Oude Wetering
 The Netherlands
 +31(0)71 33 103 36
 +31(0)71 33 172 43
 E Mail : info@AATA.nl
 website : WWW.AATA.nl

distributed by: